

SCR_DE

	REF / ART.NR		ABMESSUNGEN										DRUCKBELASTUNG	
		Sh	A	B	H	M	L	F	m	n	o	d	LAST	FEDERWEG
	mm.												kg.	mm.
SCR	SCR100M12NR40	40	80	60	38	M12	100	120	11	14	11	14	35	4,0±1,0
	SCR100M12NR45	45	80	60	38	M12	100	120	11	14	11	14	45	4,0±1,0
	SCR100M12NR55	55	80	60	38	M12	100	120	11	14	11	14	70	4,0±1,0
	SCR100M12NR65	65	80	60	38	M12	100	120	11	14	11	14	100	4,0±1,0
	SCR100M12NR75	75	80	60	38	M12	100	120	11	14	11	14	180	4,0±1,0
	SCR140M16NR35	35	103,5	75	52	M16	140	186	13	30	20	13	80	5,0±1,0
	SCR140M16NR45	45	103,5	75	52	M16	140	186	13	30	20	13	110	5,0±1,0
	SCR140M16NR55	55	103,5	75	52	M16	140	186	13	30	20	13	160	5,0±1,0
	SCR140M16NR65	65	103,5	75	52	M16	140	186	13	30	20	13	275	5,0±1,0
	SCR140M16NR75	75	103,5	75	52	M16	140	186	13	30	20	13	500	5,0±1,0
	SCR182M20NR35	35	132	112	71	M20	182	230	18	30	26	18	225	6,0±1,0
	SCR182M20NR45	45	132	112	71	M20	182	230	18	30	26	18	400	6,0±1,0
	SCR182M20NR55	55	132	112	71	M20	182	230	18	30	26	18	700	6,0±1,0
	SCR182M20NR65	65	132	112	71	M20	182	230	18	30	26	18	800	6,0±1,0
SCR182M20NR75	75	132	112	71	M20	182	230	18	30	26	18	1200	6,0±1,0	

SCR100

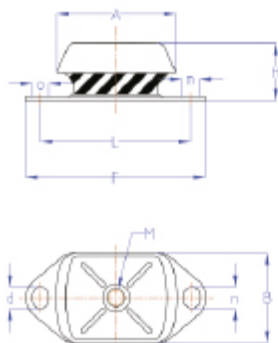

SCR140

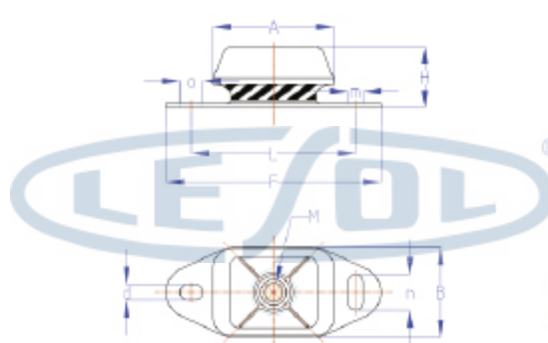

SCR182

