

AMORTIGUADORES ANTIVIBRATORIOS**AMORTIGUADOR DIÁBOLO-SILENTBLOCK**DIABOLOS

| | REF / ART.NR | | DIMENSIONES | | | | | | COMPRESIÓN | | CIZALLA | |
|---------|--------------|-----|-------------|-----|------|------|-----|------|------------|----------|----------|----------|
| | | Sh | ØA | B | ØE | D | C | I | CARGA | FLECHA | CARGA | FLECHA |
| | | | mm. | | | | | | kg. | mm. | kg. | mm. |
| SR-N | SR00N | 60 | 20 | 19 | 13 | M-06 | 15 | | 12 | 4,0±1,0 | 2 | 4,0±0,5 |
| | SR0NM8 | 50 | 40 | 28 | 20 | M-08 | 30 | | 40 | 5,5±1,0 | 7 | 5,5±1,0 |
| | SR0N | 50 | 40 | 28 | 20 | M-10 | 25 | | 40 | 5,5±1,0 | 7 | 5,5±1,0 |
| | SR1N | 50 | 58 | 44 | 24 | M-08 | 20 | | 70 | 8,5±1,0 | 10 | 8,5±1,0 |
| | SR2N | 50 | 58 | 44 | 38 | M-08 | 20 | | 130 | 8,5±1,0 | 25 | 8,5±1,0 |
| | SR4N | 50 | 60 | 60 | 48 | M-10 | 25 | | 150 | 10,0±1,0 | 20 | 12,0±1,5 |
| | SR5N | 50 | 80 | 70 | 68 | M-14 | 35 | | 350 | 14,0±1,5 | 65 | 14,0±1,5 |
| | SR6N | 50 | 95 | 76 | 76 | M-16 | 42 | | 450 | 15,0±2,0 | 75 | 15,0±2,0 |
| | SR7N | 50 | 108 | 75 | 97 | M-16 | 42 | | 600 | 15,0±2,0 | 140 | 15,0±2,0 |
| SR8N | 50 | 130 | 85 | 117 | M-16 | 42 | | 900 | 17,0±2,0 | 185 | 17,0±2,0 | |
| T | 3376 | 60 | 30 | 25 | 24 | M-08 | 20 | | 60 | 5,0±1,0 | 8 | 5,0±1,0 |
| | 3230 | 60 | 60 | 36 | 37 | M-10 | 25 | | 250 | 7,0±1,0 | 40 | 7,0±1,0 |
| | 3231 | 60 | 60 | 43 | 38 | M-10 | 25 | . | 250 | 9,0±1,0 | 30 | 9,0±1,0 |
| MR-N | MR0NM8 | 50 | 40 | 28 | 20 | M-08 | 30 | 6 | 40 | 5,5±1,0 | 7 | 5,5±1,0 |
| | MR0N | 50 | 40 | 28 | 20 | M-10 | 25 | 7 | 40 | 5,5±1,0 | 7 | 5,5±1,0 |
| | MR2N | 50 | 57 | 44 | 38 | M-08 | 25 | 6 | 130 | 8,5±1,0 | 25 | 8,5±1,0 |
| | MR4N | 50 | 60 | 60 | 48 | M-10 | 25 | 7 | 150 | 10,0±1,0 | 20 | 10,0±1,0 |
| | MR5N | 50 | 80 | 70 | 68 | M-14 | 35 | 9 | 350 | 14,0±1,5 | 65 | 14,0±1,5 |
| | MR6N | 50 | 95 | 76 | 76 | M-16 | 42 | 14 | 450 | 15,0±2,0 | 75 | 15,0±2,0 |
| | MR7N | 50 | 108 | 75 | 97 | M-16 | 42 | 14 | 600 | 15,0±2,0 | 140 | 15,0±2,0 |
| | MR8N | 50 | 130 | 85 | 117 | M-16 | 42 | 14 | 900 | 17,0±2,0 | 185 | 17,0±2,0 |
| | HR0NM8 | 50 | 40 | 28 | 20 | M-08 | | 6 | 40 | 5,5±1,0 | 7 | 5,5±1,0 |
| HR0N | 50 | 40 | 28 | 20 | M-10 | | 7 | 40 | 5,5±1,0 | 7 | 5,5±1,0 | |
| HR2N | 50 | 57 | 44 | 38 | M-08 | | 6 | 130 | 8,5±1,0 | 25 | 8,5±1,0 | |
| HR4N | 50 | 60 | 60 | 48 | M-10 | | 7 | 150 | 10,0±1,0 | 20 | 12,0±1,0 | |
| 3617 | 60 | 70 | 58 | 52 | M-12 | | 10 | 350 | 11,0±1,0 | 70 | 11,0±1,0 | |
| 3356 | 60 | 80 | 65 | 72 | M-12 | | 8,5 | 600 | 13,0±1,5 | 120 | 13,0±1,5 | |
| HR5N | 50 | 80 | 70 | 48 | M-14 | | 9 | 350 | 14,0±1,5 | 65 | 14,0±1,5 | |
| 3866RED | 60 | 90 | 52 | 82 | M-12 | | 8,5 | 850 | 10,0±1,0 | 170 | 10,0±1,0 | |
| 3866 | 60 | 90 | 80 | 79 | M-12 | | 8,5 | 750 | 16,0±2,0 | 130 | 16,0±1,5 | |
| HR6N | 50 | 95 | 76 | 76 | M-16 | | 14 | 450 | 15,0±2,0 | 75 | 15,0±2,0 | |
| 3867 | 60 | 105 | 85 | 91 | M-14 | | 11 | 1200 | 17,0±2,0 | 240 | 17,0±2,0 | |
| HR7N | 50 | 108 | 75 | 97 | M-16 | | 14 | 600 | 15,0±2,0 | 140 | 15,0±2,0 | |
| HR8N | 50 | 130 | 85 | 117 | M-16 | | 14 | 900 | 17,0±2,0 | 185 | 17,0±2,0 | |
| 3868 | 60 | 130 | 95 | 117 | M-16 | | 14 | 1800 | 19,0±2,0 | 320 | 19,0±2,0 | |
| R-N | R 4-N | 50 | 60 | 57 | 48 | M-10 | 25 | | 150 | 10,0±1,0 | | |
| | R 5-N | 50 | 80 | 65 | 68 | M-14 | 35 | | 350 | 14,0±1,5 | | |
| | R 6-N | 50 | 95 | 73 | 76 | M-16 | 42 | | 450 | 15,0±2,0 | | |
| TH-N | TH 4-N | 50 | 60 | 58 | 48 | M-10 | | 7 | 150 | 10,0±1,0 | | |
| | TH 5-N | 50 | 80 | 65 | 68 | M-14 | | 9 | 350 | 14,0±1,5 | | |
| | TH 6-N | 50 | 95 | 73 | 76 | M-16 | | 14 | 450 | 15,0±2,0 | | |

SR-N

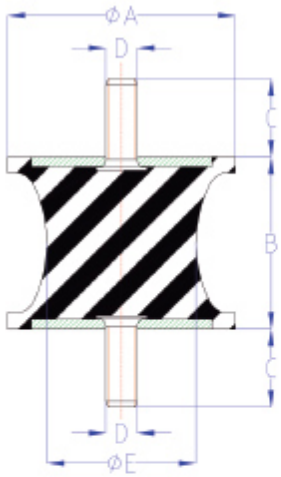

T

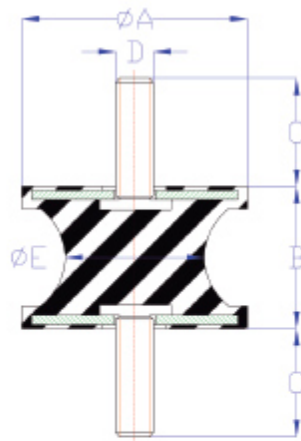

MR-N

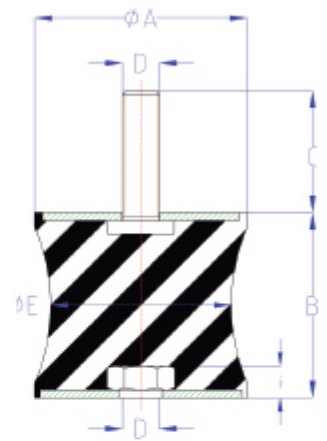

HR-N

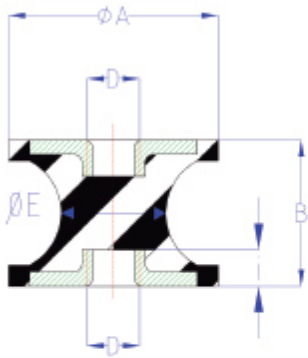

R-N

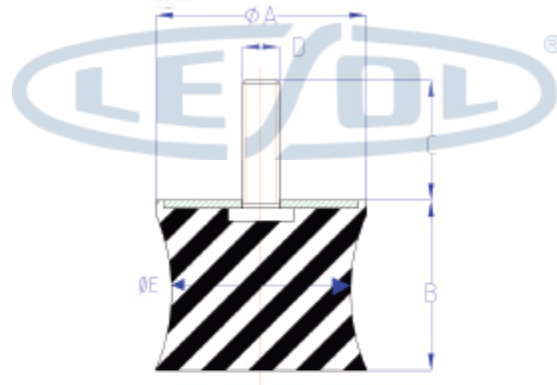

TH-N

